

Some Recent Results For MW Antenna Arrays

Dallas Lankford, 11/4/09, rev. 2/11/10

Recently Wellbrook dual MW arrays were tested on the Washington State coast. Although the most recent new Wellbrook array was a dual flag array, it was called it a Super Loop array. Nevertheless, it is a variant of my MW dual flag arrays which I have used here in North Louisiana since December 2008. The Super Loop (= single big flag) was developed based on the hypothesis that the tall vertical ends would improve reception of long-distance MW signals which were assumed to arrive at low angles. The hypothesis was not tested before an article about the Super Loop was published in Pop Comm. However, now Bruce Conti has stated that the hypothesis is false. By testing different sizes, down to 10'x20' (slightly smaller than mine), Bruce found that there is no advantage to a single larger than needed flag. Mark Connelly has down sized flags further with his tiny 6'x6' flag which he calls a Micro-SuperLoop (an oxymoron).

Dual flag arrays have been used since at least 2003 in the 160 meter ham band by Doug Waller, [NX4D](#), who developed a rotatable 160 meter band version. Jose Carlos DaSilva, [N4IS](#), further developed the dual Waller array, including a larger rotatable dual flag array for greater 160 meter sensitivity, and a rotatable horizontal 160 meter dual flag array on a tall tower for lower noise. While making preparations for testing a quad flag array at Grayland in April 2009, I found that delta flag elements were easier to transport and erect. Delta flag antennas were developed by [K6SE](#) as simplified flag antennas, requiring one mast instead of two. I built my first delta flag arrays in February 2009 to simplify construction of my first quad flag array. I called these phased arrays by their generic names, abbreviated DFA, QFA, DDFA, and QDFA.

It was surprising to read that the large Wellbrook dual flag array which he tested had overload problems. Details of the overloading were not given. In any case, it lays to rest Andrew Ikin's previous remarks to me that flag and delta flag arrays are insensitive. Presumably an appropriate size for the W DFA will eventually be found so that overload is not a problem. (Hint: Just make the large flag elements regular sized.)

A few weeks before the W DFA was tested, a Wellbrook dual K9AY array was tested, but it was not satisfactory for reasons unknown. It is widely believed that the pattern of a K9AY antenna with fixed terminating resistor changes as ground characteristics change. It is also widely believed that flags and delta flags are ground independent, but they have turned out not to be ground independent after all as was discovered during tests by Bjarne Mjelde and Odd-Jorgen Sagdahl a few weeks ago with a QDFA at Kongsfjord; see the September 2009 discussions on Bjarne's blog [here](#) where it was reported that radials are necessary for good QDFA nulls when the ground is extremely poor like at Kongsfjord. The low band QDFA insensitivity observed at Kongsfjord has yet to be explained or resolved, but could also be due to the extremely poor ground at Kongsfjord.

Some limited comparisons were made between the WD-K9AY array and a narrow diamond quad delta flag array a few weeks ago. It was found that in some cases the WD-K9AY had somewhat better splatter reduction than the NDQDFA, but on at least one split frequency the NDQDFA produced TP audio while the WD-K9AY produced no audio. Those comparisons were inconclusive because not enough recordings were made for a thorough comparison. The favorable performance of the WD-K9AY compared to the NDQDFA based on those limited comparisons does not surprise me because as I pointed out previously in my NDQDFA article the nulls of a NDQDFA are not as good as the nulls of a QDFA. As a matter of fact, the nulls of a NDQDFA tested here in North Louisiana were often not as good as the nulls of a dual flag array. Guy Atkins' tests of a NDQDFA at Grayland recently confirmed that the lackluster performance of the NDQDFA is not accidental and not due to contamination of nearby wires (which may have been a problem here in North Louisiana). Unless some way can be found to improve the NDQDFA nulls, it is a loser for MW DX compared to DFA's, DDFA's and QDFA's. Don't hold your breath. As it has turned out, the NDQDFA is another case where EZNEC predicts a wonderful pattern, but in the real world it is a flop as a MW splatter reducing antenna.

The WD-K9AY array has been described on the Wellbrook web site, where it was announced last February shortly after I published my article on dual and quad flag arrays in [The Dallas Files](#). The WD-K9AY array uses a variable phaser. But as I have pointed out previously, the null pattern of a terminated loop array cannot be optimized with a variable phaser. Perhaps Wellbrook will eventually announce a scaled down "Dual Super

Loop” array, which would merely be a dual flag array like I have been using for almost a year. Of course, mine uses a fixed phaser for optimal nulls. Perhaps the current Wellbrook phaser will eventually be replaced by a fixed phaser.

It is interesting that it has been recently concluded what I already knew and have said previously, namely that dual flag and dual delta flag arrays are excellent MW DX antennas. This has been demonstrated a number of times, including here in North Louisiana since December 2008 and at Grayland in April 2009 when a dual delta flag array was used in place of the QDFA for one of the four nights. As you will see from the loggings below, the Grayland DDFA did a very respectable job.

A schematic and diagram of the Grayland DDFA is given in a figure below followed by some of the Grayland DDFA loggings. Two of the four QDFA antenna elements were used, the two nearest “DX central,” room 15 of the Grayland Motel. The two lead ins were 200', almost long enough to make it into room 15; they were plugged into one section of the QDFA phaser which had been moved to just under the window of room 15. A short length of coax as brought through the window to a p-p Norton transformer feedback preamp which was connected to a Perseus SDR.

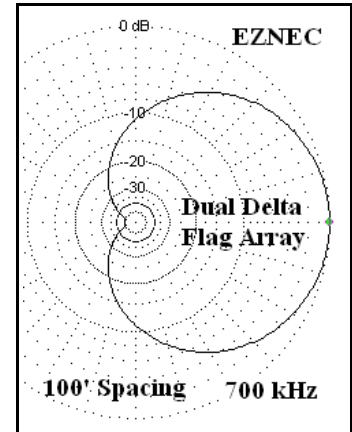

Additional information about flag and delta flag MW arrays may be found in articles in [The Dallas Files](#).

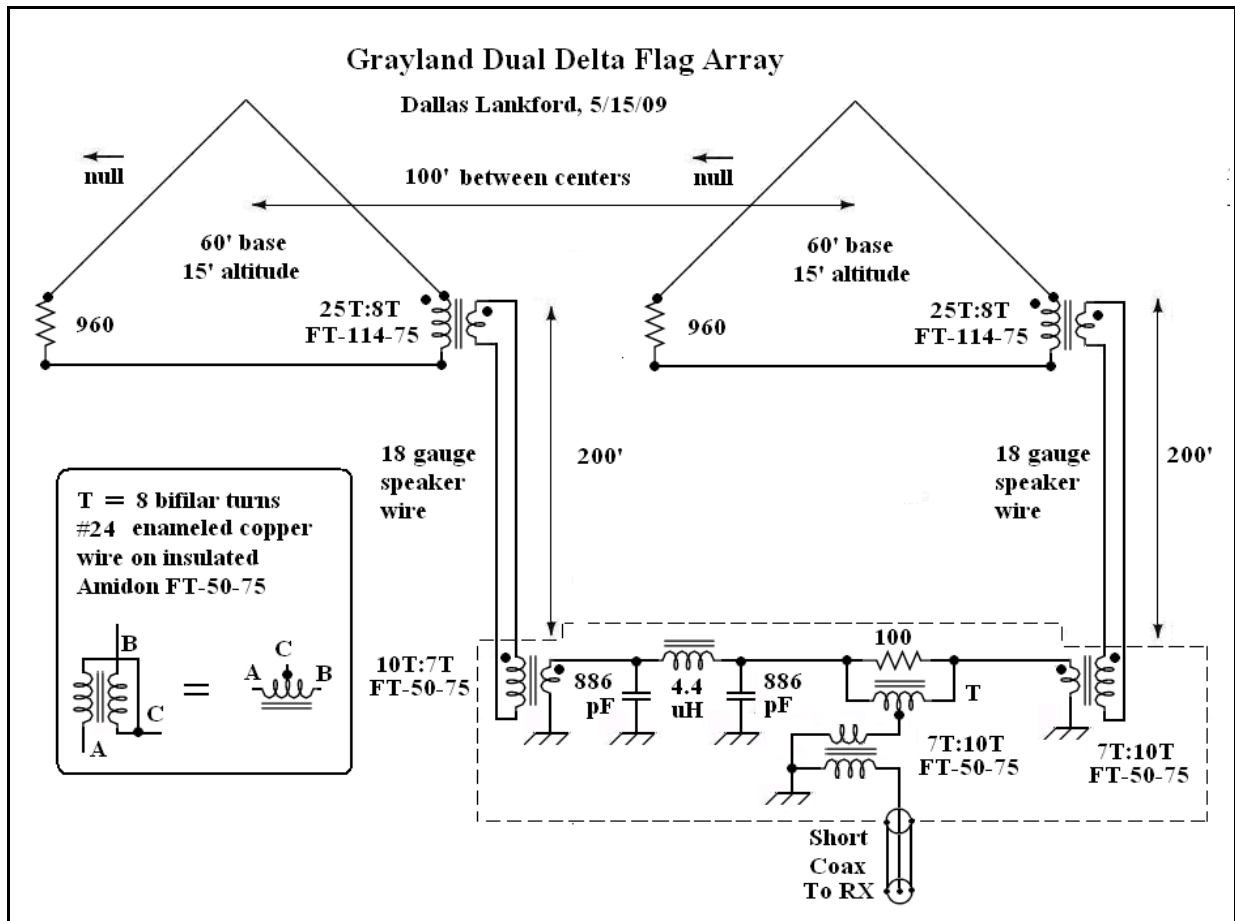

Some Of The 4/21/09 Grayland Dual Delta Flag Array Loggings

**receiver = Perseus,
antenna = dual delta flag array,
preamp = 10 dB gain p-p Norton,
computer = Clevo D901C quad,
recording = BlacX external caddy,
IOGear Express Card /34,
1.5 Tb external HD,**

- 550 Alaska**, Anchorage, KTZN, IDed as “AM Five Fifty KTZN Anchorage, This is The Zone,” about 1200, 4/21
- 560 Alaska**, Kodiak, KVOK, IDed as “AM Five Sixty KVOK Kodiak,” about 1300, 4/21
- 567 New Zealand**, Wellington, EZ listening music, //963 about 0739, 4/21
- 576 Russia**, Oyash, R. Mayak (at 1 MW Oyash dominates the other Russians on this frequency) about 1100, 4/21, with Moscow Nights interval signal, weak, but the IS was easily heard and the language had the right sound and cadence for Russian
- 590 Alaska**, Anchorage, KHAR, IDed as “KHAR Five Ninety, Anchorage,” about 1000, 4/21
- 594 Australia**, Horsham, male talker, over and under New Zealand, about 0840 – 0850, 4/21
- 594 Japan**, Tokyo, //729, NHK1 interval signal about 1300, 4/21
- 594 New Zealand**, various, female talker, //612//1251 about 0840 – 0850, 4/21
- 612 New Zealand**, Christchurch, female talker, //594//1251, about 0840 – 0850, 4/21
- 620 Alaska**, Homer, KGTL, 0859, 4/21, IDed as “KGTL Homer,” strong interference from at least two others on frequency, a mess
- 630 Alaska**, Juneau, KJNO, IDed “The Capital's Information Station, Six Thirty, KJNO, Juneau, Alaska,” about 1200, 4/21
- 640 Alaska**, Bethel, KYUK, IDed as “Hello, I am [unintelligible name] from Bethel, Alaska, [unintelligible] KYUK Six Forty AM in Bethel, Alaska,” about 1100, 4/21
- 648 Russia** Ussuriysk, VoR, poor, interval signal (Pictures at an Exhibition, AKA "Great Gate of Kiev") at about 1300, 4/21
- 650 Alaska**, Anchorage, KENI, IDed as “News Radio Six Fifty KENI,” about 0700, 4/21
- 670 Alaska**, Dillingham, KDLG, about 0629, 4/21, “KDLG” ID followed by the weather report, strong over KBOI Boise
- 670 Hawaii**, Hilo, KPUA, IDed as “I am Gordon Deal reminding you that The Wall Street Journal This Morning will continue right after the latest news on Sixty Seven AM KPUA Hilo, your source for news, sports, and information,” about 1300, 4/21, strong, clear, and almost alone on the frequency
- 680 Alaska**, Barrow, KBRW, IDed as “You are tuned to North [unintelligible] Public Radio, Six Eighty KBRW Barrow,” about 1312, 4/21, but now I can't find this ID on the 4/21 recording anywhere near 1312, I know I heard Barrow, but apparently I made an error in the time or date or both when writing my notes
- 693 Japan**, Tokyo, // 774, English lessons, short musical interlude just before ToH, time pips, 4/21
- 702 Australia**, various, (Sydney, 2BL, presumed) ABC musical fanfare at ToH, followed by ABC news with male and female, weak, 1300 and later, 4/21
- 729 Japan**, Nogaya, //594, NHK1 interval signal about 1300, 4/21
- 738 Tahiti**, Papeete, as early as 0550, but not very clear until around 0700 and later, mostly male and female French talkers, 4/21
- 738 Taiwan**, Baisha, BEL2, 100 kW, Yuye Guangbo Diantai (Taiwan Area Fishery Broadcasting Station), nice male or female Chinese singing with EZ listening music, 1252 and later, 4/21, mostly extremely weak, //1143
- 747 Japan**, Sapporo, //774, English lessons, short musical interlude just before ToH, time pips, 4/21
- 750 Alaska**, Anchorage, KFQD, IDed as “Seven fifty KFQD News Talk, Seven Fifty,” about 0700, 4/21
- 760 Hawaii**, Honolulu, KGU, on the DDFA, IDed with “You are listening to AM Seven Sixty, KGU, Hawaii's Christian Talk,” 0559, 7/21
- 770 Alaska**, Valdez, KCHU, IDed as “KCHU, Public Radio for Valdez, Prince William Sound, and the Copper River Valley,” about 0700, 4/21

774 Japan, Akita, //1386 and lots of others, English lessons, short musical interlude just before ToH, time pips, 4/21
780 Alaska, Nome, KNOM, IDed as “KNOM in Nome,” about 0900, 4/21
790 Alaska, Glennallen, KCAM, IDed as “Great radio for the great land, this is The Voice Of The Copper River Valley, KCAM, Glennallen,” about 0900, 4/21
792 Australia, Brisbane, weak or faded most of the 4/21 recording
800 Alaska, Juneau, KINY, IDed as “Alaska's Capital City, Hometown Radio,” about 0900, 4/21
820 Alaska, Fairbanks, KCBF, ESPN program, IDed as “Eight Twenty Sports Fairbanks,” about 0700 4/21
828 Australia, Geraldton Bluff, presumed, ABC musical fanfare about 1300, weak, under Japan, 4/21
828 Japan, Osaka, //774, English lessons, short musical interlude just before ToH, time pips, 4/21
850 Alaska, Nome, KICY, Voice Of The Arctic, religious song just before 1300, 4/21, then IDed by a fast talking female as “[unintelligible] KICY Nome”
855 Australia, various, ABC musical fanfare about 1300, weak, 4/21
873 Japan, Kumamoto, //774, English lessons, short musical interlude just before ToH, time pips, 4/21
882 New Zealand, Auckland, EZ listening music, //963 about 0716, 4/21
891 Japan, Sendai, NHK1 interval signal about 1300, 4/21
920 Alaska, Soldotna, KSRM, IDed as “News Talk Ninety Two KSRM,” about 0700, 4/21
930 Alaska, Ketchikan, KTKN, IDed as “Nine Thirty Ketchikan, Alaska,” about 0700, 4/21
940 Hawaii, Waipahu, KKNE, off key female singer in Hawaiian with accompanying music, non-stop through the top of the 0600 hour, continued for quite some time, then a second (?) female singer, signal strength fair to poor, finally a male singer in Hawaiian with music, very nice, signal much stronger, continued through top of the hour again with no ID, but eventually about 0703 an English ID “AM Nine Forty KKNE Waipahu, Hawaii”
963 China, usually given as unknown location, but Dalian is 5 times as strong as any other Chinese on this frequency, also, Dalian has been reported in the past as a CNR or CRI station on 963, time pips 3 low and 1 high, CNR or CRI interval signal, about 1300, 4/21
963 New Zealand, Canterbury, EZ listening music, 0650 – 0900 and later, 4/21, // 981 about 0654, //882 about 0716
972 South Korea, Dangjin, HLCA, //1134, 4/21, about 1300, partial KBS interval signal after time pips at ToH
981 New Zealand, Kaikohe, EZ listening music, //963 about 0654, 4/21
1008 New Zealand, Tauranga, male talker, //1035//1044//1098//1107//1278, fair to good, 0730 – 0750 and later, 4/21
1008 Japan, Osaka, presumed, ABC jingle surfaced out of a mess about 1300, 4/21
1017 China, Changchun, presumed, nice oriental music, followed by easy listening non-oriental music, then CNR interval signal at about 1200, 4/21
1017 Japan, Fukuoka, JOLB, // 0774, about 1300, 4/21
1017 Philippines, Davo City, DXAM, here it is August 21 and just yesterday I got around to listening for DXAM on my 4/21 recording made from the dual delta flag array, about 1248 a fast male Filipino talker appeared, followed by a somewhat off key female singer, then about 1259 a “Radyo Rapido” ID, followed by a badly off key female singer “Falling In Love With You” in English, and about 1301 “DXAM, Radyo Rapido, diyes disisiyete (ten seventeen)” ID, after which the signal weakened until about 1310 when another off key singer was noted, followed by a lengthy announcement of “winning numbers,” namely various one digit lottery numbers, a mention of Super Lotto, and a lottery number consisting of six 2 digit numbers, also mentioned was “9 pm drawing” which is consistent with a 1300 UTC drawing, more details could have been included, this was the clearest of the receptions of DXAM during the 4 days I was at Grayland.
1017 Tonga, Nuku'alofa, presumed, female talker in English before 0730, 4/21, faded down but then faded up again with nice harmony island music about 0750
1035 New Zealand, Wellington, male talker, //1008//1044//1098//1107//1278 and later, mostly weak, 0730 – 0750, 4/21
1044 China, Changzhou, presumed, it is 10 times the power of the other Chinese on frequency, time pips 3 low 1 high, CNR or CRI interval signal, about 1300, 4/21
1044 New Zealand, Dunedin, male talker, //1008//1035//1098//1278 and later, fair to occasionally good, 0730 –

0750, 4/21

1080 Alaska, Anchorage, KUDO, IDed as “This is Alaskan Progressive Voice News Ten Eighty KUDO Anchorage,” about 0700, 4/21

1089 Japan, Sendai, //774, English lessons, short musical interlude just before ToH, time pips, 4/21

1098 Marshall Islands, Majuru, V7AB, Radio Marshalls, presumed, male talkers in island language, about 0730, 10/21, quite clear, but then faded after a few minutes, back again 0736 stronger and clearer than before, some of the talking in the background, including a woman's voice, was New Zealand

1098 New Zealand, Christchurch, male talker, //1008//1035//1044//1107//1278 and later, about 0730 – 0750, 4/21, mostly weak and under Marshall Islands, but occasionally quite clear

1107 New Zealand, Tauranga, male talker, //1008//1035//1044//1098//1278, weak, but enough audio to determine //, about 0740 – 0750, 4/21

1125 Japan, various, //774, English lessons, short musical interlude just before ToH, time pips, 4/21

1134 Japan, Tokyo, strong throughout the evening up to 1300 and later, 4/21

1134 South Korea, Kimpo, //972, 4/21, about 1300, partial KBS interval signal after time pips at ToH, under Japan

1140 Alaska, Soldotna, KSLD, IDed as “This is Eleven Forty KSLD, The King, Soldotna,” about 0700, 4/21

1143 Taiwan, Baisha, BEL3, 100 kW, Yuye Guangbo Diantai (Taiwan Area Fishery Broadcasting Station), nice male or female Chinese singing with EZ listening music, 1252 and later, 4/21, mostly extremely weak, //738

1170 Alaska, North Pole, KJNP, “You are tuned to One One Seven O, your Gospel Radio, KJNP, North Pole, Alaska,” about 0700, 4/21, strong and clear, not nearly as strong or clear an hour earlier, but nevertheless IDable with phrases like “Tonight at North Pole is [unintelligible],” “Not all Alaska,” and “This is Alaska.”

1170 Philippines, Poro Point, DWVA, Voice of America, complete interval signal with a few notes missing under splatter at about 1100, 4/21, 7 note part of the VOA IS with 2 notes missing due to splatter at about 1300, all underneath Bellingham, WA, a Korean (presumed), and a 3rd very weak English language station, or maybe it was VOA in English as some of their announcements are in English, but at times before and after 1100 there was a 2nd oriental talker which may have been VOA

1205.970 China, Yanbian, 200 kW, presumed (although there is no other Chinese with anything like 200 kW power per asiawaves), male and female talkers in presumed Chinese before and after 1100, mention of “CNR” at about 1100, 4/21

1242 Japan, Tokyo, JOLF, Japanese male talkers, 3 low coo coo pips and one high at about 1300, 4/21

1251 New Zealand, Auckland, female talker, //594//612 about 0840 – 0850, 4/21

1251 Russia, Razdolnoye, 500 kW per asiawaves, VoR interval signal (Pictures at an Exhibition) at about 1300, 4/21

1278 New Zealand, Eltham or Napier-Hastings, //1008//1035//1044//1098//1107 and later, (only Napier reported once previously from Grayland), talk, 0730 – 0750, 4/21

1287 Japan, Sapporo, strong, with some fades, about 0850 – 0900, mainly male and female talkers in Japanese, occasional jingles, 4/21

1323 China, Huadian, presumed, 600 kW per new asiawaves addition April 2009, CNR interval signal about 1300, 4/21

1386 Japan, various, //774, English lessons, short musical interlude just before ToH, time pips, 4/21

1386 South Korea, Mokpo, HLAM, MBC chimes interval signal, about 1200, 4/21

1475 Malaysia, Kota Kinabalu, transmitter on with 1 kHz tone about 1047, 4/21, few details at sign on because of weak signal strength, weak to fair to occasional good signal strength throughout the 1047 to about 1334 transmission period, sign off with weak but audible choir version of the Malaysian national anthem starting about 1332, transmitter off immediately about 1334.

1503 Micronesia, Kosrae Island, Tofal, V6AJ, Voice of Kosrae, faded up about 0711, 4/21 with harmony singing island music using the DDFA, weakened and then faded completely by 716, reappeared weakly with island music and singing about 0753, brief male talker about 0758 followed by female talker, quite strong at times, heavy Seattle splatter which started just before the top of the hour spoiled any chance for an ID, weak island music again after 0800, faded until island music with singing in harmony slowly faded up again around 0938, quite good at times by 0941, faded completely by 0955, but then appeared again about 1014 sporadically

with brief episodes of island music and singing in harmony, sometimes way under Japan. Even though no definite ID was heard, who else could it be? Again 4/22, occasionally quite clear with island music between 0700 and 1100. These 1 kW Micronesian receptions are among the high points of my trip to Grayland.

1503 Japan, Akita (with other synchros perhaps helping a little), JOUK, // 594, about 1015, 4/21, sometimes over presumed Micronesia, // 594; again 4/22 over and under Micronesia between 1000 and 1100

1548 Australia, Emerald, weak or faded on most of the 4/21 recording, but occasional crystal clear audio such as around 1345

1566 South Korea, Cheju Island, presumed, I did not try for an ID, good throughout the 4/21 evening

1575 Thailand, Ban Phachi, Voice of America, 4/21, quite clear, several VOA interval signals around 1300, then just after 1300 the following announcements “You are listening to the Voice of America, Washington, DC,” “Welcome to the Voice of America in Vietnamese,” and then into Vietnamese programming, good to very good signal

1593 Japan, NHK2 synchros, with English lessons, //774, about 1300, 4/21

1593 New Zealand, Christchurch, presumed, EZ listening American rock and roll, 0711 – 0715 and later, 4/21

1602 Japan, Yokote, //774, English lessons, short musical interlude just before ToH, time pips, 4/21

1701.03 Australia, Brisbane, Radio Brisvaani 400 W, presumed due to off frequency, about 1300 and later, unknown language heard, maybe an island language, not Hindi, occasional music, one with drums and harmony singing about 1322, 4/21